

Important Safeguards:

When using electrical equipment, basic safety precautions should always be followed including the following:

Read and follow all safety instructions

1. **Danger** - Risk of shock - Disconnect power before installation
2. **Product must be installed in accordance with CEC or your local electrical code.** If you are not familiar with these codes and requirements, consult a qualified electrician.

SAVE THESE INSTRUCTIONS FOR FUTURE REFERENCE

Installation Instructions:

Figure 1.

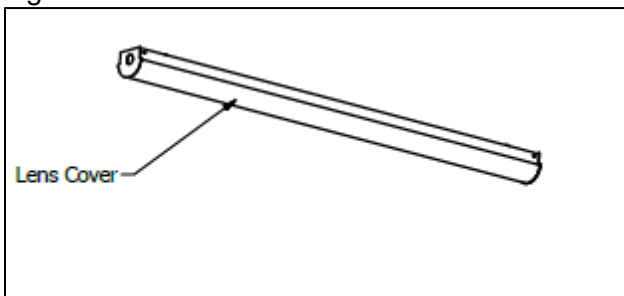

Figure 2.

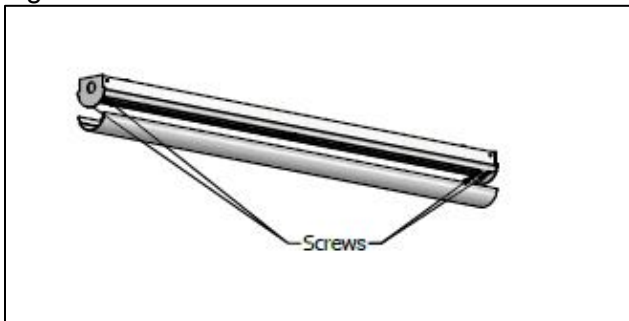
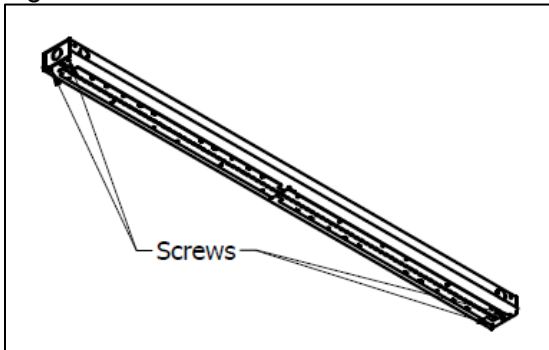

Figure 3.



Notes:

- Available luminaire lengths are 2', 4', and 8'.

BLSP Options Available:

- Motion Sensor

Luminaire Installation:

BLSP with Lens

Step 1:

Remove the lens cover from the housing. (See Figure 1)

Step 2:

Unscrew the screws at the ends of the fixture to remove the LED panel. (See Figure 2)

Step 3: Mounting & Wiring

Suspension or Surface Mounting Holes (C). Embosses for Surface mounting (B). 7/8inch knock-outs for wiring. Knock-out in end-cap can be used for row mounting (A). (See Figure 4) (Continuous row mounting not available for a BLSP with motion Sensor)

Step 4:

Reattach the LED panel and snap on the lens cover.

BLSPC

Step 1:

Unscrew the screws at the ends of the fixture to remove the LED Panel. (See Figure 3)

Step 2: Mounting & Wiring

Suspension or Surface Mounting Holes (C). Embosses for Surface Mounting (B). 7/8 inch knock-out for wiring. Knock-out in end cap can be used for row mounting (A). (See Figure 4) This luminaire cannot be installed with less than 0.5" clearance on each side of the fixture, (See Figure 5) but the ends may be flush with the walls. (See Figure 6)

Figure 4.

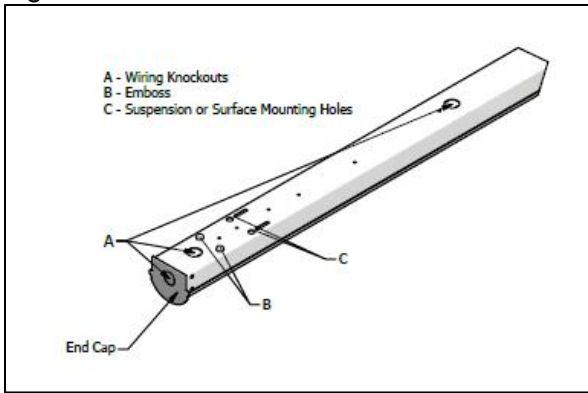

Step 3:
Reattach the LED panel. (Do not install lens)

Figure 5.

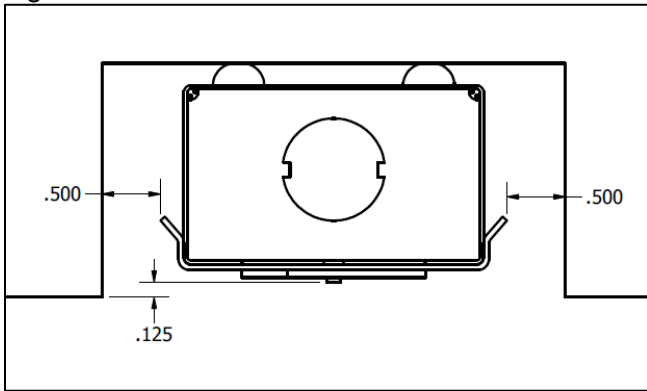
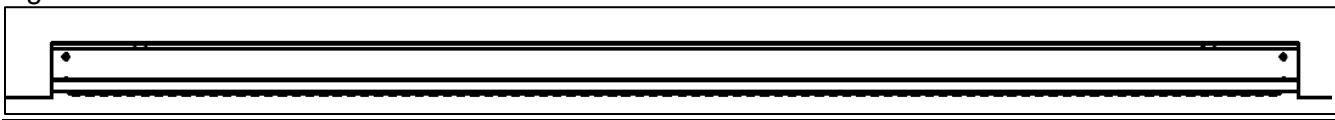

Figure 6.



Electrical Connections:

Step 1:

Make the following Electrical Connections:

For 120-277V / 347V Applications make the following Electrical Connections:

- Connect the black luminaire lead to the line supply lead
- Connect the white luminaire lead to the neutral supply lead
- Connect the green or green and yellow ground lead to the supply ground lead

Dimming Option:

- Connect the violet dimming positive lead to the supply dimming positive lead
- Connect the grey dimming negative lead to the supply dimming negative lead

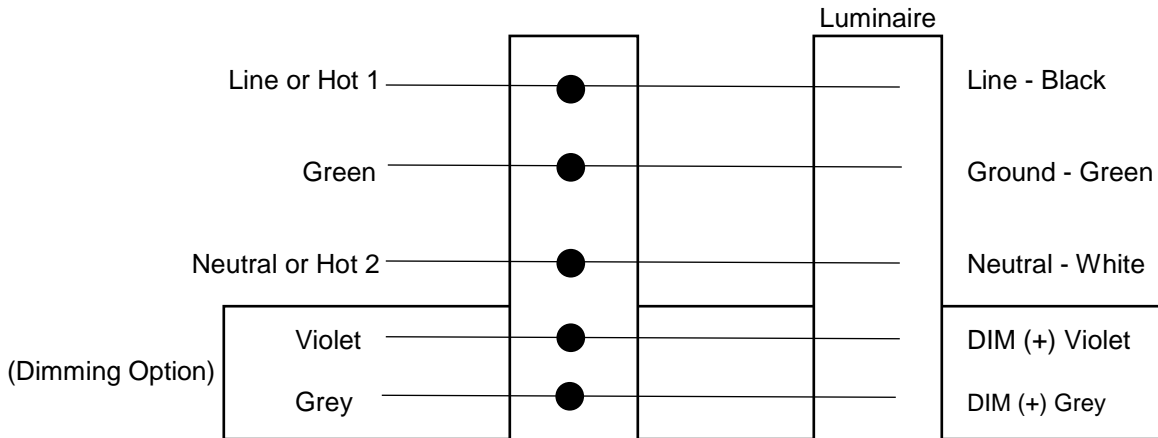

For 16/4 both circuits must be connected to the same branch circuit, i.e. turning off the branch circuit protection will turn off both circuits of the luminaire.

Step 2:

BLSP - Reinstall LED panel and lens

BLSPC - Reinstall LED panel (Do not install any lenses)

Electrical Disconnect Instructions:

The above electrical connections for the line 1 and neutral are made using the electrical disconnect that is connected to the LED driver. The connections are made as follows below, note that the disconnect is color coded for circuit wiring.

- Black to Live
- White to Neutral

The intended wire sizes are as follows, with an 11-13 mm jacking length.

- 2 x AWG 18-12 **solid wire** per pole
- 2 x AWG 16-12 \leq 19 **stranded wire** per pole

If a wire is connected incorrectly the only way to remove the wire is by twisting the electrical disconnect and pulling firmly on the incorrect wire.